

banchi di
controllo,
centratori
e tavole



softmetal
italiana s.r.l.

653



8/03

652



8/03

975



8/03

657



8/04

654 - 658



8/04

659



8/04

651 - 656



8/05

605



8/06

606

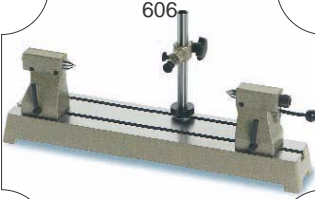

8/07

607



8/07

602



8/08

613



8/08

615



8/08

www.mconti.com



Tutti i preset nuovi in internet - chiedere preventivo
Alle neuen Einstellgeraete im Internet - Angebot erfragen
 All new preset models see website - ask for offer

614



8/09

616



8/09

617



8/10

611

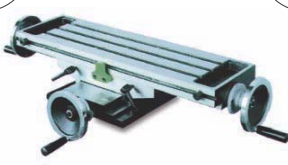

8/10

612



8/10

620



8/10

539



8/11

674



8/11

675

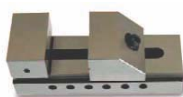

8/12

676



8/12

671 - 672

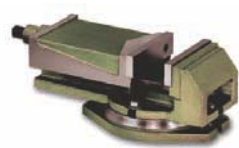

8/12

679



8/12

678



8/13

677



8/13

600



8/13

Centratori meccanici Midway - acciaio rettificato - piatti lappati - utilizzo in rotazione max. 600 rpm - gambo Ø10 contatti Ø10 o doppi Ø10+4 - astuccio plastica

Mechanische Kantentaster Midway - geschliffener Stahl - gelaeppte Teller - Gebrauch in Rotation max. 600 UPM - Einspannschaft Ø10 Taster Ø10 oder doppelt Ø10+4 - Plastiketui

Mechanical edge finders Midway - grinded steel - lapped disks use in rotation max. 600 rpm - shank Ø10 - contacts Ø10 or double Ø10+4 - plastic box

Codice N° <i>Bestell Nr.</i> <i>Order code</i>	Gambo Ø <i>Schaft Ø</i> <i>Shank Ø</i>	Contatto Ø <i>Kontakt Ø</i> <i>Contact Ø</i>	Lungh. <i>Laenge</i> <i>Length</i>
009.671	10	10	90
009.672	10	10+4	90
009.673	Molla - <i>Feder</i> - <i>Spring</i>		

Variante 009.672 in esecuzione amagnetica
Variante 009.672 in antimagnetischer Ausfuehrung
Varity 009.672 in antimagnetic execution

653.097	10	10+4	90
009.673	Molla - <i>Feder</i> - <i>Spring</i>		

Variante 009.671 contatto in ceramica
Variante 009.671 Kontakt in Keramik
Varity 009.671 contact in ceramic

653.091	10	10	90
653.092	Molla - <i>Feder</i> - <i>Spring</i>		

Centratori meccanici Midway - acciaio rettificato - utilizzo da fermo - gambo Ø20 - sfera Ø10 - led luminoso - ast. legno
Kantentaster Midway - geschliffener Stahl - Gebrauch nur im Stillstand Einspannschaft Ø20 - Kugel Ø10 - Leuchtanzeige - Holzetui
Mechanical edge finders Midway - grinded steel - use only in arrest shank Ø20 - sfere Ø10 - luminous led - wooden box

Codice N° <i>Bestell Nr.</i> <i>Order code</i>	Gambo Ø <i>Schaft Ø</i> <i>Shank Ø</i>	Contatto Ø <i>Kontakt Ø</i> <i>Contact Ø</i>	Lungh. <i>Laenge</i> <i>Length</i>
009.659	20	10	125
009.667	Led/molla	<i>Led/Feder</i> - <i>Led/spring</i>	
999.998+999.999	Pila	<i>Batterie</i> - <i>Battery</i>	
009.662	20	10	160
009.667	Led/molla	<i>Led/Feder</i> - <i>Led/spring</i>	
999.998	Pila	<i>Batterie</i> - <i>Battery</i>	
009.663	20	10	160
009.668	Beep/Led	<i>Beep/Led</i> - <i>Beep/Led</i>	
999.998	Pila	<i>Batterie</i> - <i>Battery</i>	

Centratori 3-dimensionali - comparatore centesimale Ø58 gambo Ø20 - puntalino con gambo in ceramica standard L27 Ø4 (optional tipo lungo L69 Ø8) - scatola polistirolo
3-dimensionale Kantentaster - Messuhr Ø58 x 0.01mm Einspannschaft Ø20 - Tasteinsatz mit Keramikschaft L27 Ø4 (als Zubehoer langes Modell L69 Ø8) - Polistirolverpackung
3-dimensional edge finders - dial gauge Ø58 x 0,01mm shank Ø20 - probe tip with ceramic shank L27 Ø4 (optional long model L69 Ø8) - foam packing

Codice N° <i>Bestell Nr.</i> <i>Order code</i>	Gambo Ø <i>Schaft Ø</i> <i>Shank Ø</i>	Contatto Ø <i>Kontakt Ø</i> <i>Contact Ø</i>	Lungh. <i>Laenge</i> <i>Length</i>
975.001	20	4 (8)	113+50

Codice N° <i>Bestell Nr.</i> <i>Order code</i>	Gambo Ø <i>Schaft Ø</i> <i>Shank Ø</i>	Contatto Ø <i>Kontakt Ø</i> <i>Contact Ø</i>	Lungh. <i>Laenge</i> <i>Length</i>
975.101	10	4 (8)	96+24,8

975.011	L27-Ø4	Puntalino- <i>Taster-Probe tip</i>	
975.012	L69-Ø8	Puntalino- <i>Taster-Probe tip</i>	

Centratori meccanici

Midway

Mechanische Kantentaster
Mechanical edge finders

653



Centratori luminosi

Midway

Kantentaster mit Leuchtanzeige
Edge finders with led

652



Centratori 3D ad orologio

F.H.

3-D Kantentaster mit Messuhr
3-D edge finders with dial

975

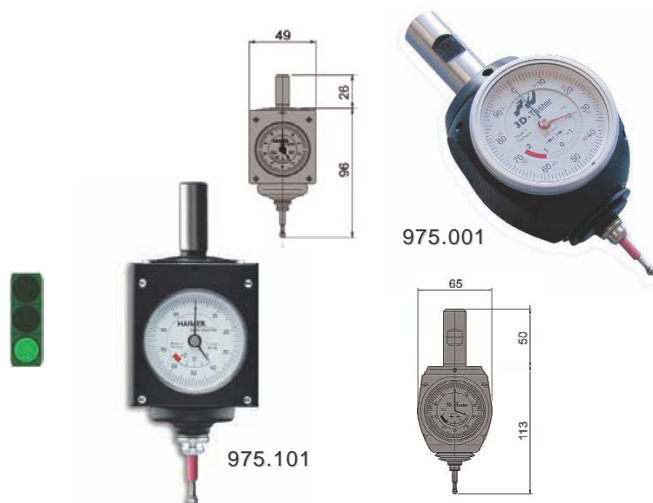

VOGEL

Preset luminosi magnetici

657

Hoeheneinstellgeraete h50 magnetisch mit Led
Height presetters h50 magnetic with led



009.645

Preset altezza Vogel - h50 - base magnetica - led luminoso rosso - astuccio legno

Hoeheneinstellgeraete Vogel - h50 - magnetische Basis - rote Leuchtkontrolle mit Led - Holzetui

Height presetters Vogel - h50 - magnetic base - red luminous control led - wooden box

Codice N° <i>Bestell Nr.</i>	Base Ø <i>Basis</i>	Contatto Ø <i>Kontakt</i>	Altezza <i>Hoehe</i>
<i>Order code</i>	<i>Base Ø</i>	<i>Contact Ø</i>	<i>Height</i>
009.645	54	13	50
009.645L	Led ricambio - <i>Ersatzled</i> - <i>Spare led</i>		
999.990	Pila - <i>Batterie</i> - <i>Battery</i>		



Vtec

Preset magnetici con comparatore

658

Magnetische Hoeheneinstellgeraete mit Uhr
Magnetic height presetters with dial

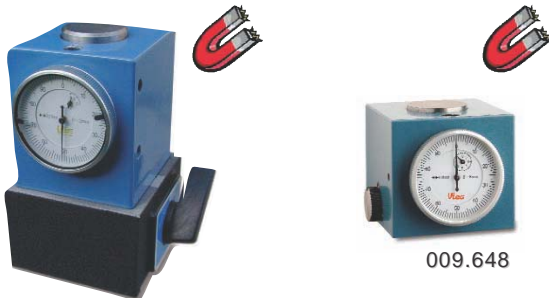

009.649

009.648

Preset altezza Vtec - corpo alluminio - comparatore 0,01mm Ø40 incorporato - rotella di azzeramento - h50 base magnetica permanente opp. h100 con magnete a leva - astuccio legno

Hoeheneinstellgeraete Vtec - Aluminiumkoerper - eingebaute Messuhr 0,01mm Ø40 - Einstellrad - h50 Basis mit Festmagnet oder h100 mit Zusatzschaltmagnet - Holzetui

Height presetters Vtec - aluminium body - incorporated dial gauge 0,01mm Ø40 - setting wheel - h50 with permanent magnetic base or h100 with additional switch magnet - wooden box

Codice N° <i>Bestell Nr.</i>	Base <i>Basis</i>	Contatto Ø <i>Kontakt</i>	Altezza <i>Hoehe</i>
<i>Order code</i>	<i>Base</i>	<i>Contact Ø</i>	<i>Height</i>
009.648	52x52	26	50
009.649	60x60	26	100



Midway

Preset con comparatore

654

Hoeheneinstellgeraete mit Uhr
Height presetters with dial



009.641

009.640

009.642

Preset altezza Midway - corpo alluminio - comparatore 0,01 Ø40 incorporato - h50 con o senza base magnetica permanente opp. h100 con magnete a leva - astuccio legno

Hoeheneinstellgeraete Midway - Aluminiumkoerper - eingebaute Messuhr 0,01mm Ø40 - h50 Basis mit oder ohne Festmagnet oder h100 mit Zusatzschaltmagnet - Holzetui

Height presetters Midway - aluminium body - incorporated dial gauge 0,01mm Ø40 - h50 with or without permanent magnetic base or h100 with additional switch magnet - wooden box

Codice N° <i>Bestell Nr.</i>	Base <i>Basis</i>	Contatto Ø <i>Kontakt</i>	Altezza <i>Hoehe</i>
<i>Order code</i>	<i>Base</i>	<i>Contact Ø</i>	<i>Height</i>
009.640	50x50	32	50
009.641	50x50 m	32	50
009.642	54x57 m	32	100



VOGEL

Preset magnetici con comparatore

659

Magnetische Hoeheneinstellgeraete mit Uhr
Magnetic height presetters with dial



659.734

Preset altezza Vogel - corpo acciaio - comparatore di alta qualità Kaefer 0,01mm Ø40 incorporato - h100 - base magnetica permanente - scatola plastica - in esaurimento

Hoeheneinstellgeraete Vogel - Stahlkoerper - eingebaute Qualitaets-Messuhr Kaefer 0,01mm Ø40 - h100 - Basis mit Permanentmagnet - Plastikschachtel - im Ausverkauf

Height presetters Vogel - steel body - incorporated high quality dial gauge Kaefer 0,01mm Ø40 - h100 - permanent magnetic base - carton box - sellout

Codice N° <i>Bestell Nr.</i>	Base <i>Basis</i>	Contatto Ø <i>Kontakt</i>	Altezza <i>Hoehe</i>
<i>Order code</i>	<i>Base</i>	<i>Contact Ø</i>	<i>Height</i>
659.734	50x50	35	100
659.734p	Comparatore - <i>Messuhr</i> - <i>Dial gauge</i>		



Con codice 659.733 sono disponibili ancora alcuni pezzi color nero con base senza magneti e comparatore standard
Unter Best.Nr. 659.733 sind noch einige Geraete in schwarzer Farbe ohne Magnete und mit Standardmessuhr erhaeltlich
Under code number 659.733 are still available few pieces in black colour without magnets in base and with standard dial gauge

Preset altezza Vogel - corpo acciaio - comparatore di alta qualità Kaefer 0,01mm Ø40 esterno - h50 - base magnetica permanente - scatola plastica - in esaurimento
Hoeheneinstellgeraete Vogel - Stahlkoerper - Qualitaets-Messuhr Kaefer 0,01mm Ø40 aussen - h50 - Basis mit Permanentmagnet Plastikschachtel - im Ausverkauf
Height presets Vogel - steel body - external high quality dial gauge Kaefer 0,01mm Ø40 - h50 - permanent magnetic base - carton box - sellout

Codice N°	Base	Contacto Ø	Altezza
<i>Bestell Nr.</i>	<i>Basis</i>	<i>Kontakt Ø</i>	<i>Hoehe</i>
<i>Order code</i>	<i>Base</i>	<i>Contact Ø</i>	<i>Height</i>
659.730	50x50	19	50

659.734p Comparatore - *Messuhr* - *Dial gauge*



Preset magnetici con comparatore

Magnetische Hoeheneinstellgeraete mit Uhr
Magnetic height presets with dial

VOGEL
651



659.730

Preset altezza Midway - corpo acciaio - comparatore 0,01 esterno o incorporato - h50 - base con o senza magneti permanenti - astuccio legno
Hoeheneinstellgeraete Midway - Stahlkoerper - Messuhr 0,01mm aussen oder eingebaut - h50 - Basis mit oder ohne Permanentmagnet - Holzetui
Height presets Midway - steel body - dial gauge 0,01mm incorporated or external - base with or without permanent magnets - wooden box

Codice N°	Base Ø	Contacto Ø	Altezza
<i>Bestell Nr.</i>	<i>Basis Ø</i>	<i>Kontakt Ø</i>	<i>Hoehe</i>
<i>Order code</i>	<i>Base Ø</i>	<i>Contact Ø</i>	<i>Height</i>
009.646	63	31	50
009.647	63	31	50

Magnetico - *magnetisch* - *magnetic*

009.644 63 31 50



Preset con comparatore

Hoeheneinstellgeraete mit Uhr
Height presets with dial

Midway
656



009.644

009.647

009.646

Preset utensili M.Conti - a causa dell'evoluzione troppo rapida di questi tipi di apparecchi preferiamo mostrarVi tutti i modelli aggiornati in internet
www.mconti.com
www.vogel.it "novità appena arrivati"
Hoeheneinstellgeraete M.Conti - wegen der zu schnellen Evolution dieser Geraete bevorzugen wir, Ihnen die neuen Modelle im Internet vorzustellen
www.mconti.com
www.vogel.it "novità appena arrivati"
Tool presets M.Conti - due to the too fast evolution of this kind of instruments we prefer to show You the last updated models in our websites
www.mconti.com
www.vogel.it "novità appena arrivati"

Preset utensili

Voreinstellgeraete
Tool preset

m. conti

Vari modelli per ogni esigenza dal tastatore meccanico, passando dai proiettori fino alle telecamere a colori
Diverse Modelle fuer alle Ansprueche vom Tastergeraet ueber Profilprojektoren bis zur Farbkamera
Various models for all requirements starting from touch probe models over profile projectors until colour cameras



Tutti i preset M.Conti sono forniti con 1 bussola ISO a scelta - bussole HSH ed altri disponibili come optional
Alle Voreinstellgeraete M.Conti werden mit 1 Werkzeugaufnahme SK nach Wahl geliefert - Aufnahmen HSK und andere sind als Zubehoer erhaeltlich
All tool presets M.Conti are delivered with 1 cone holder SK at Your choice - Holders HSK and others are available as optionals

VOGEL

Banchi di concentricità 200-350

605

Rundlaufpruefgeraete 200-350
Concentricity bench centers 200-350

Banchi di concentricità Vogel made in Germany - interasse punte 200 o 350 - altezza punte 50 opp. 75 (solo 75 con prismi per alberi 5-20) - incl. 1 portacomparatore - cartone
Rundlaufpruefgeraete Vogel made in Germany Spitzenweite 200 oder 350 - Spitzenhoehe 50 oder 75 (nur 75 mit Prismen fuer Wellen 5-20) - incl. 1 Messuhrhalter - Karton
Concentricity bench centers Vogel made in Germany - width between points 200 or 350 - height of points 50 or 75 (only 75 with prisms for tubes 5-20) - incl. 1 dial holder - carton box

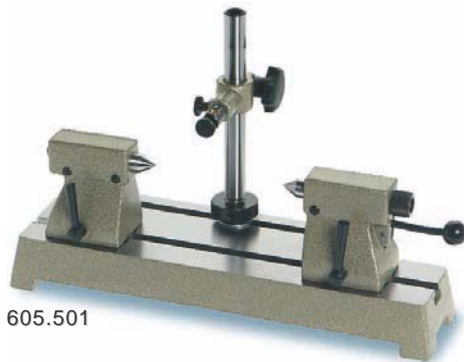

605.501

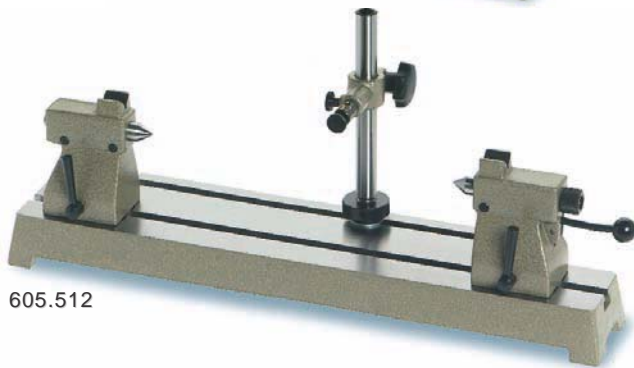

605.512



605.571



605.531

605.532



605.561



605.562



605.541



605.542



605.551



605.552*



605.553



605.521*

Supporto singolo sinistro
Portapinza non compreso
Einzelreitstock links
Spannzange nicht inbegriffen
Single tailstock left
collet not included

Codice N° <i>Bestell Nr.</i> <i>Order code</i>	Interasse <i>Spitzenweite</i> <i>Width pt.</i>	Altezza pt. <i>Hoehe Sp.</i> <i>Height pt.</i>	Banco <i>Tisch</i> <i>Table</i>
200			
605.501	200	h50	350x110
605.502	200	h75 V	350x110

* 4/5 giorni - * 4/5 Tage - * 4/5 days

Codice N° <i>Bestell Nr.</i> <i>Order code</i>	Interasse <i>Spitzenweite</i> <i>Width pt.</i>	Altezza pt. <i>Hoehe Sp.</i> <i>Height pt.</i>	Banco <i>Tisch</i> <i>Table</i>
350			
605.511	350	h50	500x110
605.512	350	h75 V	500x110

Base sciolta - <i>Grundplatte</i> - <i>Single base</i>			
605.570*	200 x 110		T10H7
605.571	350 x 110		T10H7
605.572	500 x 110		T10H7

605.570 utilizzabile con 1 contropunta sola
605.570 nur mit 1 Reitstock verwendbar
605.570 useable with 1 tail stock only

Coppia punte - <i>Reitstoecke</i> - <i>Tail stocks</i>			
605.531	h50	T10	- - -
605.532	h75 V	T10	Ø 5-20

Coppia blocchi - <i>Bloecke</i> - <i>Blocks</i>			
605.561	VV	T10	Ø 5-20
605.562	OO	T10	Ø 2-20

Portacomparatore - <i>Uhrstaender</i> - <i>Dial holder</i>			
605.541	h220 Ø 16	mov.	T10
605.542	h200 Ø 16	fix	T10

Ø 16 Contropunte - <i>Spitzen</i> - <i>Points</i>			
605.551	V 3-15	V 3-15	V 3-15
605.552*	Foro 3,8	Loch 3,8	Hole 3,8
605.553	Standard	Standard	Standard

Supp. portapinza - <i>Rs Spannzange</i> - <i>Ts Collet</i>			
605.521*	h50	F10 0,5-7	H10
605.522*	h75	F10 0,5-7	H10
605.523*	h50	F14 1-10	H10
605.524*	h75	F14 1-10	H10

Banchi di concentricità Vogel made in Germany - interasse punte 450 - altezza punte 100/150 senza prismi opp. 150 con prismi per alberi 8-32 - incl. 1 portacomparatore - cartone
Rundlaufpruefgeraete Vogel made in Germany - Spitzenweite 450 Spitzenhoehe 100/150 ohne Prismen oder 150 mit Prismen fuer Wellen 8-32 - incl. 1 Messuhrhalter - Karton
 Concentricity bench centers Vogel made in Germany - width between points 450 - height of points 100/150 without prisms or 150 with prisms for tubes 8-32 - incl. 1 dial holder - carton box

Banchi di concentricità 450-650



Rundlaufpruefgeraete 450-650
 Concentricity bench centers 450-650

Codice N° <i>Bestell Nr.</i> <i>Order code</i>	Interasse <i>Spitzenweite</i> <i>Width pt.</i>	Altezza pt. <i>Hoehe Sp.</i> <i>Height pt.</i>	Banco <i>Tisch</i> <i>Table</i>
450			
606.501	450	h100	700x180
606.511	450	h150	700x180
606.512	450	h150 V	700x180

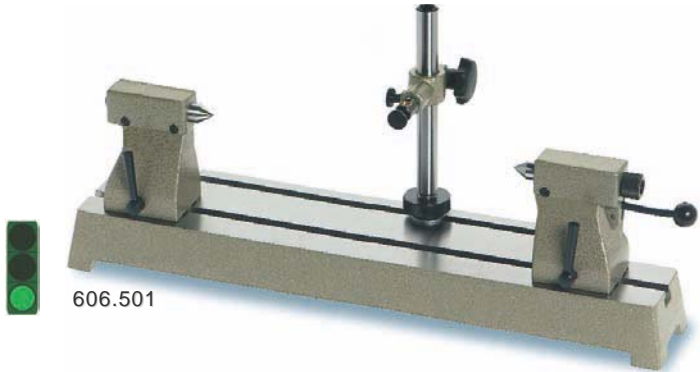

Banchi di concentricità con base in granito
Rundlaufpruefgeraete mit Granitbasis
 Concentricity bench centers with granite basis

Codice N° <i>Bestell Nr.</i> <i>Order code</i>	Interasse <i>Spitzenweite</i> <i>Width pt.</i>	Altezza pt. <i>Hoehe Sp.</i> <i>Height pt.</i>	Banco <i>Tisch</i> <i>Table</i>
650	Granito	- <i>Granit</i> - <i>Granite</i>	
607.501*	650	h200	1110x180



* 4/5 giorni - * 4/5 Tage - * 4/5 days

Codice N° <i>Bestell Nr.</i> <i>Order code</i>	Base sciolta <i>Grundplatte</i> - <i>Single base</i>	Banco <i>Tisch</i> <i>Table</i>
606.571	700 x 180	T12H7



Codice N° <i>Bestell Nr.</i> <i>Order code</i>	Coppia punte <i>Reitstoecke</i> - <i>Tail stocks</i>	Altezza pt. <i>Hoehe Sp.</i> <i>Height pt.</i>	Banco <i>Tisch</i> <i>Table</i>
606.531	h100	T12	---
606.532	h150	T12	---
606.533	h150 V	T12	Ø 8-32
607.534*	h200 V	T14	Ø 10-50

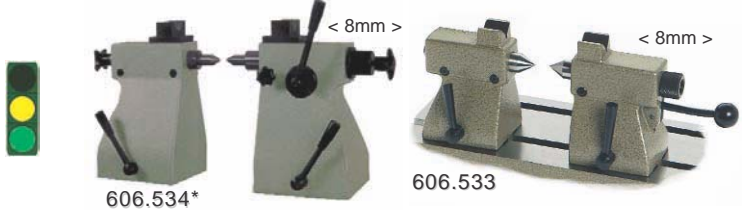

Codice N° <i>Bestell Nr.</i> <i>Order code</i>	Coppia blocchi <i>Bloecke</i> - <i>Blocks</i>	Altezza pt. <i>Hoehe Sp.</i> <i>Height pt.</i>	Banco <i>Tisch</i> <i>Table</i>
606.561*	VV	T12	Ø 5-20
606.562*	OO	T12	Ø 2-20
607.562*	OO	T14	Ø 25-150



Codice N° <i>Bestell Nr.</i> <i>Order code</i>	Portacomparatore <i>Uhrstaender</i> - <i>Dial holder</i>	Altezza pt. <i>Hoehe Sp.</i> <i>Height pt.</i>	Banco <i>Tisch</i> <i>Table</i>
606.541*	h220 Ø 22	mov.	T12
606.542*	h400 Ø 22	fix	T12
607.541*	h420 Ø 35	mov.	T14



Codice N° <i>Bestell Nr.</i> <i>Order code</i>	Contropunte <i>Spitzen</i> - <i>Points</i>	Altezza pt. <i>Hoehe Sp.</i> <i>Height pt.</i>	Banco <i>Tisch</i> <i>Table</i>
606.551*	V 8-45	V 8-45	V 8-45
606.552*	Foro 3,8	Loch 3,8	Hole 3,8
606.553*	Standard	Standard	Standard



Codice N° <i>Bestell Nr.</i> <i>Order code</i>	Supp. portapinza <i>Rs Spannzanze</i> - <i>Ts Collet</i>	Altezza pt. <i>Hoehe Sp.</i> <i>Height pt.</i>	Banco <i>Tisch</i> <i>Table</i>
606.522*	h100	F14 1-10	H12
606.523*	h100	F20 1-16	H12

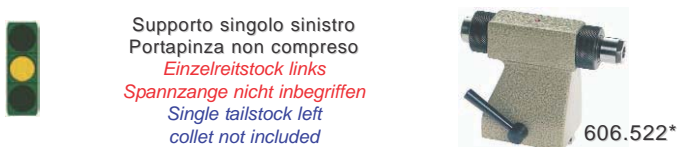

Supporto singolo sinistro
 Portapinza non compreso
Einzelreitstock links
Spannzanze nicht inbegriffen
 Single tailstock left
 collet not included

Vtec
602

Banchi di concentricità 500-1000

Rundlaufpruefgeraete 500-1000
Concentricity bench centers 500-1000

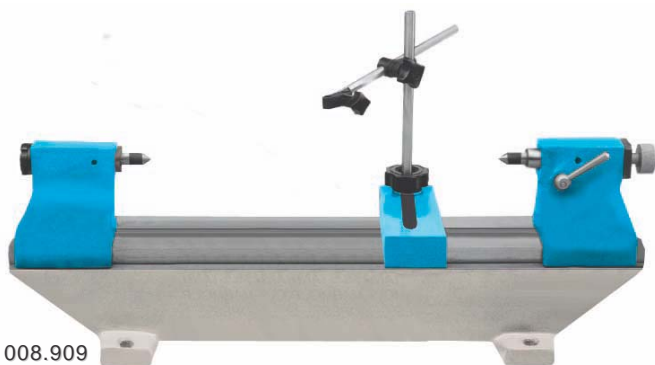

008.909

Banchi di concentricità Vtec - interasse punte 500 o 1000
1 punta fissa + 1 punta mobile - altezza punte 170
incl. 1 portacomparatore - cassa legno
Rundlaufpruefgeraete Vtec - Spitzenweite 500 oder 1000
1 feststehender + 1 beweglicher Reitstock - Spitzenhoehe 170
incl. 1 Messuhrhalter - Holzkiste
Concentricity bench centers Vtec - width between points 500
or 1000 - 1 fix + 1 moveable tail stock - height of points 170
incl. 1 dial holder - wooden box

Codice N° Bestell Nr. Order code	Interasse Spitzenweite Width pt.	Altezza pt. Hoehe Sp. Height pt.	Banco Tisch Table
008.909	500	170	L 930
008.910	1000	170	L 1460

Vtec
613

Divisori orizzontali - verticali

Waagerechte und senkrechte Teilapparate
Horizontal and vertical direct dividing heads

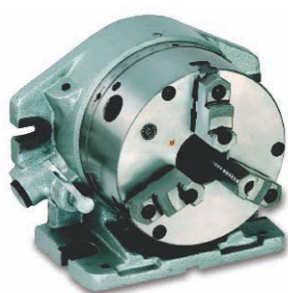

008.579

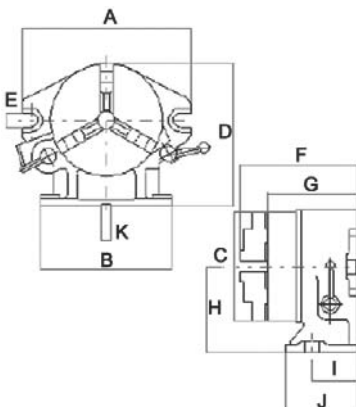

Divisori orizzontali e verticali Vtec - divisioni a scatto
rapido 2-3-4-6-8-12-24 - completo di mandrino - peso pezzi
fino a 50kg in orizzontale e 10kg in verticale - cassa legno
Waagerechte und senkrechte Direkt-Teilapparate Vtec
Teilungen 2-3-4-6-8-12-24 fach - Gewicht der Bearbeitungsteile
bis zu 50kg waagerecht und 10kg senkrecht - Holzkiste
Horizontal and vertical direct dividing heads Vtec - divisions
2-3-4-6-8-12-24 - complete with lathe chuck - max. load up to
50kg horizontal and 10kg vertical - wooden box

Codice N° Bestell Nr. Order code	Mandrino Spannfutter Lathe chuck	Passaggio Durchgang Center hole	Centro Zentrum Center
008.579	Ø 210	Ø 62	h 149,25

A	B	C	D	E	F	G	H	I	J	K	Foro Loch Hole	Kg
310	255	210	259,25	18	214	171,5	149,25	80	130	16	62	52

Midway
615

Tavole a dividere basculanti

Schwenkbare Teiltische
Tilting rotary tables



008.598

Tavole a dividere basculanti Midway - divisioni con manovella
e nonio opp. dischi (optional) - peso pezzi fino a 200/250 kg
in orizzontale e 100/125 kg in verticale - cassa legno
Schwenkbare Teiltische Midway - Teilungen mit Rad
und Nonius oder Teilscheiben (Zubehoer) - Bearbeitungsteile bis
zu 200/250 kg waagerecht und 100/125 kg senkrecht - Holzkiste
Tilting rotary tables Midway - divisions with wheel and vernier or
disks (optional) - max. load up to 200/250 kg horizontal and
100/125 kg vertical - wooden box

Codice N° Bestell Nr. Order code	Mandrino Spannfutter Lathe chuck	Cono Morse Morsekegel Morse cone	Cave Nuten Slots
008.598	Ø 250	3	6 T12
008.599	Ø 320	4	6 T14

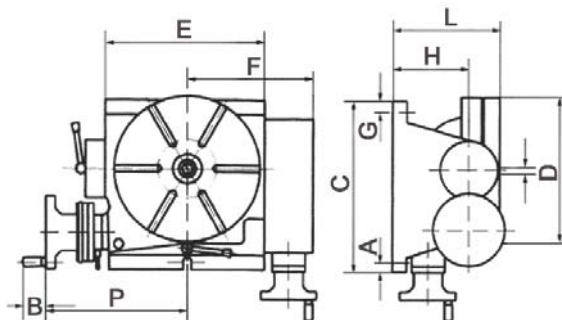

Ø mm	A	B	C	D	E	F	G	H	L	C Morse	Rapp Verh. Ratio	Cave Nuten Slots	T mm	Kg
250	14	40	310	250	252	199	14	140	205	3	1:90	6	12	78
320	16	40	380	320	322	241	18	175	255	4	1:90	6	14	133

Tavole a dividere orizzontali/verticali Midway - divisioni con manovella e nonio opp. dischi (optional) - peso pezzi vedi tabella - cassa legno - *5/6 giorni

*Waagerechte/senkrechte Teiltische Midway - Teilungen mit Rad und Nonius oder Teilscheiben (Zubehoer) - Gewicht der Bearbeitungsteile siehe Tabelle - Holzkiste - *5/6 Tage*

*Horizontal/vertical rotary tables Midway - divisions with wheel and vernier or disks (optional) - max. load of workpieces see table - wooden box - *5/6 days*

Codice N° <i>Bestell Nr.</i> <i>Order code</i>	Mandrino <i>Spannfutter</i> <i>Lathe chuck</i>	Cono Morse <i>Morsekegel</i> <i>Morse cone</i>	Cave <i>Nuten</i> <i>Slots</i>
008.581*	∅ 100	2	4 T6
008.592	∅ 160	2	4 T10
008.593	∅ 200	3	4 T12
008.594	∅ 250	3	6 T12
008.595	∅ 320	4	6 T14
008.596	∅ 400	4	6 T14
008.582*	∅ 500	5	8 T18
008.583*	∅ 630	5	8 T18

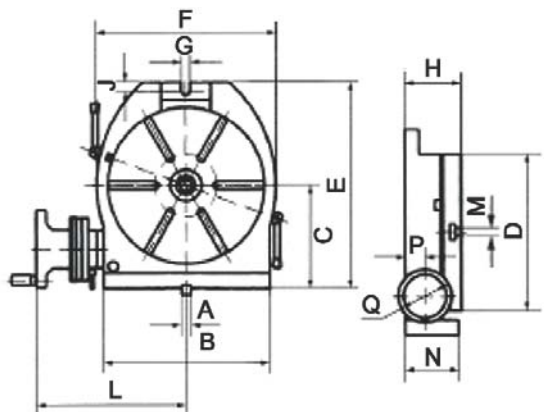

∅ mm	A	B	C	D	E	F	G	H	J	L	N	P	Q	Rapp. Verh. Ratio	Kg max. orizz.	Kg max. vertical	Kg
100	10	125	70	100	125	125	---	70	---	114	48	30	50	1:72	20	10	10
160	12	186	125	160	242	196	12	85	12	194	82	37	125	1:90	100	50	23
200	14	208	150	200	285	236	14	100	15	211	99	48	125	1:90	150	75	31
250	14	253	170	250	328	286	14	110	16	241	106	48	125	1:90	200	100	44
320	18	321	210	320	410	360	18	120	16	273	118	48	125	1:90	250	125	75
400	18	400	260	400	525	450	18	150	16	337	145	70	160	1:90	300	150	145
500	---	---	---	500	640	560	22	159	20	393	---	65	180	1:120	550	---	235
630	---	---	---	630	820	700	22	160	20	468	---	68	220	1:120	700	---	345

Contropunte Midway - regolabili in altezza - cassa legno
Reitstoecke Miday - Hoehenverstellung - Holzkiste
Tailstock Miway - adjustable in height - wooden box

Codice N° <i>Bestell Nr.</i> <i>Order code</i>	Tavole ∅ <i>Tische ∅</i> <i>Tables ∅</i>	h min. <i>h min.</i> <i>h min.</i>	h max. <i>h max.</i> <i>h max.</i>
008.590	160	97	131
008.588	200-250	140	180
008.589	320	180	224

Coppia dischi a dividere con accessori (sost. manovella)
Paar Teilscheiben mit Zubehoer (Austausch Kurbelrad)
Couple of dividing disks with accessories (substitution wheel)

Codice N° <i>Bestell Nr.</i> <i>Order code</i>	Tavole ∅ <i>Tische ∅</i> <i>Tables ∅</i>	Rapporto <i>Verhaeltnis</i> <i>Ratio</i>	∅ int/est <i>∅ inn/auss</i> <i>∅ int/ext</i>
008.586	160-320	1:90	38/130
A : 34-37-38-39-41-43-44-50-52-56-61			
B : 46-47-49-51-53-54-57-58-59-62-64			
008.587	400	1:90	53/170
A : 34-37-38-39-41-43-44-50-52-56-61			
B : 46-47-49-51-53-54-57-58-59-62-64			
008.585	500-630	1:120	53/170
A : 33-34-37-38-39-41-43-44-50-52-56-61			
B : 46-47-49-51-53-54-57-58-59-62-63-64			

Tavole girevoli orizzontali (verticali)

Midway

Waagerechte (senkrechte) Teiltische
Horizontal (vertical) rotary tables

614



008.581*

Tavole 008.582/3 (500 e 630) solo orizzontali
Tische 008.582/3 (500 und 630) nur waagerechte Ausfuehrung
Tables 008.582/3 (500 and 630) only horizontal type



008.593

Accessori per tavole a dividere

Midway

Zubehoer fuer Teiltische
Accessories for rotary tables

616



008.588



008.587

Vtec
617

Mini-tavole girevoli basculanti

Drehbarer Miniteiltisch schwenkbar
Mini tilting rotary tables



008.591

Tavole girevoli Vtec - basculanti 90° - ingombro totale 190x130x140h - altezza orizzontale 100, verticale 140 lettura 1° - peso ca. 9,5kg - cassetta legno
Drehbare Miniteiltische Vtec - schwenkbar 90° - Gesamtgroesse 190x130x140h - Hoehe horizontal 100, vertical 140 Ablesung 1° - Gewicht ca. 9,5kg - Holzkiste
Mini rotary tables Vtec - tilting 90° - Total overall dimensions 190x130x140h - horizontal height 100, vertical height 140 reading 1° - approx. weight 9,5kg - wooden box



Codice N°	Mandrino	h centro	P. barra
<i>Bestell Nr.</i>	<i>Spannfutter</i>	<i>H Zentrum</i>	<i>Durchgang</i>
<i>Order code</i>	<i>Lathe chuck</i>	<i>h center</i>	<i>Passage</i>
008.591	Ø 110	70	Ø 25

Midway
611

Tavole a croce 2-D

Kreuztische 2-D
Compound sliding tables 2-D



008.521

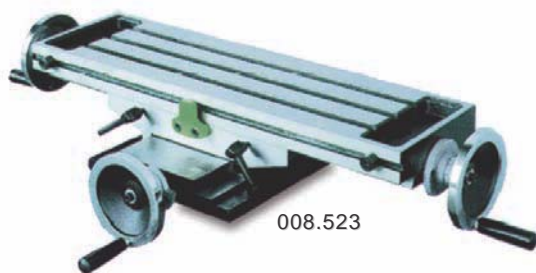
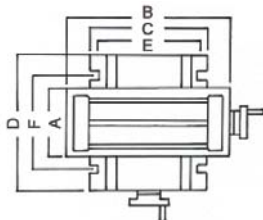

008.523

Tavole a croce Midway - movimento assi X e Y con 2/3 manovelle e nonio - 3 cave a T - tipo economico leggero 008.522 senza nonio e 2 cave a T - cartone o cassetta legno
Kreuztische Midway - Bewegung der X und Y Achse mit 2/3 Kurbeln mit Nonius - 3 T-Nuten - leichtes Billigmodell 008.522 ohne Nonius und nur 2 T-Nuten - Karton oder Holzkiste
Compound sliding tables Midway - movement X and Y axis with 2/3 wheels and vernier - 3 T-slots - light economic model 008.522 without vernier and only 2 T-slots - carton or wooden box



Codice N°	Tavolo	Spostamento	Base
<i>Bestell Nr.</i>	<i>Tisch</i>	<i>Arbeitsweg</i>	<i>Grundplatte</i>
<i>Order code</i>	<i>Table</i>	<i>Travels</i>	<i>Base</i>
008.521	185x100	50x80	130x170
008.523	590x160	145x290	280x360
008.524	730x210	160x360	280x360
<i>Economica/leggera - Leichte Ausf. - Light type</i>			
008.522	475x153	120x280	200x270

B	A	C	D	E	F	h	T	mm	Kg
185	100	130	170	115	100	100	10	0,01	16
590	160	280	360	245	230	180	12	0,05	75
730	210	280	360	245	230	180	12	0,05	86
<i>Economica/leggera - Leichte Ausf. - Light type</i>									
475	153	200	270	162	var.	128	14	no	23

Vtec
612

Tavole basculanti ± 45°

Schwenktische ± 45°
Tilting tables ± 45°

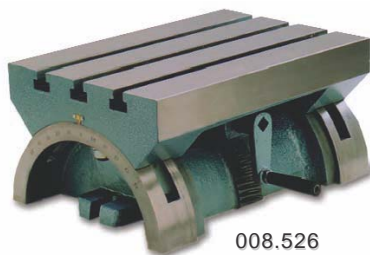

008.526

Tavole basculanti Vtec - inclinazione piano ±45° tramite manovella - nonio 1° laterale - piano rettificato con cave a T vedi tabella - cassa legno
Schwenktische Vtec - Schwenkung der Platte ±45° mit Kurbel seitlicher Nonius 1° - Oberfläche des Tisches geschliffen T-Nuten siehe Tabelle - Holzkiste
Tilting tables Vtec - movement of table ±45° with wheel vernier 1° on side arc - table surface grinded - size of T-slots see table below - wooden box



Codice N°	Tavolo x h	Cave	Kg
<i>Bestell Nr.</i>	<i>Tisch x h</i>	<i>Nuten</i>	<i>Kg</i>
<i>Order code</i>	<i>Table x h</i>	<i>Slots</i>	<i>Kg</i>
008.525	250x180x140	12	22,5
008.526	380x254x210	14	70
008.527	600x300x255	16	135

Midway
620

Smontaconi ISO

Montagebloecke ISO
Tool tightening fixture ISO



008.541

DIN 2080 + 69871 - MAS BT

Smontaconi ISO in acciaio Midway - basamento con fori di fissaggio bloccaggio cono - inclinazione 0-90° con bloccaggio - ISO o BT - HSK a richiesta - sacchetto di plastica
Montagebloecke ISO aus Stahl Midway - Grundplatte mit Befestigungsloechern - Sicherung fuer Kegel - 0-90° schwenkbar mit Blockierung ISO oder BT - HSK auf Anfrage - Plastikfolie
Tool tightening fixture ISO Midway - base with fixing holes - security sistem for tools - movement 0-90° with locking device - ISO or BT HSK on request - plastic foil



Codice N°	DIN	MAS BT	Kg
<i>Bestell Nr.</i>	<i>DIN</i>	<i>MAS BT</i>	<i>Kg</i>
<i>Order code</i>	<i>DIN</i>	<i>MAS BT</i>	<i>Kg</i>
008.540	ISO 30	BT 30	9,5
008.541	ISO 40	BT 40	10
008.542	ISO 50	BT 50	10,5

Assortimenti coppie parallele per morse - acciaio speciale temprato ca. 60±2 HRC - Precisione DIN 7168 - angolarità 0,008/100mm - parallelismo 0,01mm - astuccio legno
Saetze Parallelunterlagen fuer Schraubstoecke - gehaerteter Stahl ca. 60±2 HRC - Genauigkeit DIN 7168 - Winkelgenauigkeit 0,008/100mm - Parallelitaet 0,01mm - Holzkasten
Sets couples of parallels for vices - tempered special steel 60±2 HRC - precision DIN 7168 - rectangularity 0,008/100mm parallelisme 0,01mm - wooden box

Assortimenti coppie parallele

Midway

Saetze Paare Parallelunterlagen
Sets of couples of steel parallels

539



008.714

Codice N°	Coppie	Lunghezza	Spessore
<i>Bestell Nr.</i>	<i>Paare</i>	<i>Laenge</i>	<i>Staerke</i>
<i>Order code</i>	<i>Couples</i>	<i>Length</i>	<i>Thickness</i>
008.714	14	150	10
10x14 - 10x16 - 10x18 - 10x20 - 10x22 - 10x24 - 10x26 - 10x28 - 10x30 - 10x32 - 10x35 - 10x40 - 10x45 - 10x50			



Codice N°	Coppie	Lunghezza	Spessore
<i>Bestell Nr.</i>	<i>Paare</i>	<i>Laenge</i>	<i>Staerke</i>
<i>Order code</i>	<i>Couples</i>	<i>Length</i>	<i>Thickness</i>
008.709	9	100	4
4x10 - 4x14 - 4x18 - 4x22 - 4x26 - 4x30 - 4x34 - 4x38 - 4x42			



008.725

Codice N°	Coppie	Lunghezza	Spessore
<i>Bestell Nr.</i>	<i>Paare</i>	<i>Laenge</i>	<i>Staerke</i>
<i>Order code</i>	<i>Couples</i>	<i>Length</i>	<i>Thickness</i>
008.710	9	160	4
4x10 - 4x14 - 4x18 - 4x22 - 4x26 - 4x30 - 4x34 - 4x38 - 4x42			



Codice N°	Coppie	Lunghezza	Spessore
<i>Bestell Nr.</i>	<i>Paare</i>	<i>Laenge</i>	<i>Staerke</i>
<i>Order code</i>	<i>Couples</i>	<i>Length</i>	<i>Thickness</i>
008.720	20	100	div.
2x5 - 2x10 - 2x15 - 2x20 - 3x6 - 3x11 - 3x16 - 3x21 - 4x7 - 4x12 - 4x17 - 4x22 - 5x8 - 5x13 - 5x18 - 5x23 - 6x9 - 6x14 - 6x19 - 6x24			



Codice N°	Coppie	Lunghezza	Spessore
<i>Bestell Nr.</i>	<i>Paare</i>	<i>Laenge</i>	<i>Staerke</i>
<i>Order code</i>	<i>Couples</i>	<i>Length</i>	<i>Thickness</i>
008.724	24	125	div.
8x11 - 8x16 - 8x21 - 8x26 - 8x31 - 8x36 - 10x13 - 10x18 - 10x23 - 10x28 - 10x33 - 10x38 - 12x15 - 12x20 - 12x25 12x30 - 12x35 - 12x40 - 14x17 - 14x22 - 14x27 - 14x32 - 14x37 - 14x42			



Codice N°	Coppie	Lunghezza	Spessore
<i>Bestell Nr.</i>	<i>Paare</i>	<i>Laenge</i>	<i>Staerke</i>
<i>Order code</i>	<i>Couples</i>	<i>Length</i>	<i>Thickness</i>
008.725	24	150	div.
8x11 - 8x16 - 8x21 - 8x26 - 8x31 - 8x36 - 10x13 - 10x18 - 10x23 - 10x28 - 10x33 - 10x38 - 12x15 - 12x20 - 12x25 12x30 - 12x35 - 12x40 - 14x17 - 14x22 - 14x27 - 14x32 - 14x37 - 14x42			



Morse di precisione Midway da rettifica e di controllo ganasce con prisma orizzontale e verticale - precisione ±0,005/100mm - cartone
Praezisions-Schleif und Kontrollschraubstoecke Midway Backen mit waagerechten und senkrechten Prismen - Genauigkeit ±0,005/100mm - Karton
Precision toolmaker's and control vices Midway - jaws with vertical and horizontal prisms - threaded spindle - precision ±0,005/100mm - carton box

Morse di precisione

Midway

Praezisions-schraubstoecke
Precision toolmakers vices

674



008.515

Codice N°	L Ganasce	H	Apertura	L totale
<i>Bestell Nr.</i>	<i>L Backen</i>	<i>H</i>	<i>Spannweite</i>	<i>L gesamt</i>
<i>Order code</i>	<i>L Jaws</i>	<i>H</i>	<i>Opening</i>	<i>L all</i>
008.516	50	25	60	140
008.517	73	35	100	190
008.515	88	40	125	235
008.518	100	45	125	245
008.519	125	50	160	285
008.520	125	50	210	335



Midway

Morse rapide di precisione

675

Schraubstoecke mit Schnellverstellung
Quick clamping toolmakers vices

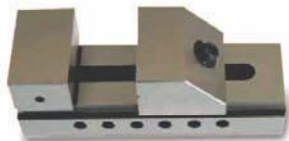

008.532

Morse rapide di precisione Midway - ganasce con doppio prisma - precisione $\pm 0,005\text{mm}$ - cartone
Präzisionsschraubstoecke Midway mit Schnellverstellung Backen mit doppeltem Prisma - Genauigkeit $\pm 0,005\text{mm}$ - Karton
Quick clamping precision toolmakers vices Midway - jaws with double prisms - precision $\pm 0,005\text{mm}$ - carton box

Codice N°	L Ganasce	H	Apertura	L totale
Bestell Nr.	L Backen	H	Spannweite	L gesamt
Ordercode	L Jaws	H	Opening	L all
008.529	26	10	25	65
008.530	50	25	65	140
008.531	73	35	100	190
008.532	100	45	125	245
008.533	125	50	160	285

Midway

Morse rapide barraseno

676

Präzisions-Sinus-Schraubstoecke
Precision sine toolmakers vices



008.509*

Morse come sopra - angolazione 0:45°
interasse rulli 100mm - cartone - * 4/5 giorni
*Präzisionsschraubstoecke wie oben - Winkeleinstellung 0:45° Rollenabstand 100mm - Karton - * 4/5 Tage*
Quick clamping precision toolmakers vices as above - angle range 0:45° - distance of rolls 100mm - carton box - * 4/5 days

Codice N°	L Ganasce	H	Apertura	L totale
Bestell Nr.	L Backen	H	Spannweite	L gesamt
Ordercode	L Jaws	H	Opening	L all
008.508*	50	25	65	140
008.509*	76	35	100	190
008.510*	100	45	125	245

Vtec

Morse macchina base girevole

671

Machinenschraubstoecke mit drehbarer Basis
Machine vices with swivel base



008.501*

Dimensioni mm		
402	182	142h
470	234	172h
512	280	186h

Morse macchina Vtec - corpo corto in ghisa e grande apertura - base girevole con 4 asole di fissaggio ganasce lisce - cartone - * 4/5 giorni
*Machinenschraubstoecke Vtec - kurzer Gusskoerper und grosse Spannweite - drehbare Basis mit 4 Montageoesen - glatte Backen - Karton - * 4/5 Tage*
Machine vices Vtec - short body in cast iron and long opening swivel base with 4 fixing slots - smooth jaws carton box - * 4/5 days

Codice N°	Ganasce	Altezza	Apertura	Peso Kg
Bestell Nr.	Backen	Hoehe	Spannweite	Gewicht
Ordercode	Jaws	Height	Opening	Weight
008.501*	160	50	180	23
008.502*	200	63	220	33
008.503*	250	63	280	65

Vtec

Morse macchina base girevole

672

Machinenschraubstoecke mit drehbarer Basis
Machine vices with swivel base

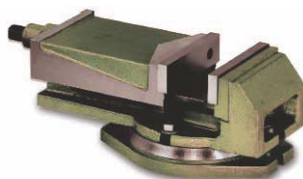

008.513*

Dimensioni mm		
260	140	105h
301	160	134h
411	222	158h
461	240	175h

Morse macchina pesanti Vtec - corpo lungo in ghisa base girevole con 2 asole di fissaggio - ganasce lisce cartone - * 4/5 giorni
*Machinenschraubstoecke Vtec schwere Ausfuehrung - langer Gusskoerper - drehbare Basis mit 2 Montageoesen - glatte Backen - Karton - * 4/5 Tage*
Machine vices Vtec heavy duty execution - long body in cast iron - swivel base with 2 fixing slots - smooth jaws carton box - * 4/5 days

Codice N°	Ganasce	Altezza	Apertura	Peso Kg
Bestell Nr.	Backen	Hoehe	Spannweite	Gewicht
Ordercode	Jaws	Height	Opening	Weight
008.511*	100	35	80	11
008.512*	125	40	100	17
008.513*	160	50	125	41
008.514*	200	63	160	52

Vtec

Morse macchina inclinabile

679

Schwenkbare Machinenschraubstoecke
Tilting machine vices with swivel base



008.506*

Dimensioni mm		
319	189	147h
383	226	160h
443	270	194h

Morse macchina pesanti Vtec - corpo lungo in ghisa base girevole con 2 asole di fissaggio - ganasce lisce inclinabile 45° - cartone - * 4/5 giorni
*Machinenschraubstoecke Vtec schwere Ausfuehrung - langer Gusskoerper - drehbare Basis mit 2 Montageoesen - glatte Backen - schwenkbar 45° - Karton - * 4/5 Tage*
Machine vices Vtec heavy duty execution - long body in cast iron - swivel base with 2 fixing slots - smooth jaws tilting 45° - carton box - * 4/5 days

Codice N°	Ganasce	Altezza	Apertura	Peso Kg
Bestell Nr.	Backen	Hoehe	Spannweite	Gewicht
Ordercode	Jaws	Height	Opening	Weight
008.504*	100	40	80	19
008.505*	125	45	100	29
008.506*	160	50	125	49

Assortimenti 58 pezzi elementi di staffaggio - dettagli vedi sotto - contenitore plastica con fondo metallico - cartone
Saetze 58 Stueck Klemmelemente - Details siehe unten
Plastikbox mit Metallrueckwand - Karton
Sets 58 pieces clamping tools - details see above - plastic container with metal back - carton box

Codice N° <i>Bestell Nr.</i> <i>Order code</i>	Pezzi <i>Stueck</i> <i>Pieces</i>	Vite <i>Schraube</i> <i>Screw</i>	dado "T" <i>T-Mutter</i> <i>T-nuts</i>
008.012	58	M12	T14
008.013	58	M12	T16
008.014	58	M14	T16
008.015	58	M14	T18
008.016	58	M16	T18
008.017	58	M16	T20



Assortimenti 58pz staffaggi

Saetze 58 Stueck Klemmelemente
Sets of 58 pieces clamping tools

Midway
678



008.014

24	4 x 6L Tiranti - <i>Zugschrauben</i> - <i>Clamping studs</i>
6	Dadi a rondella - <i>Flanschmuttern</i> - <i>Flange nuts</i>
6	Dadi a "T" - <i>T-muttern</i> - <i>T-slot nuts</i>
4	Manicotti per tiranti - <i>Verbindungsmuttern</i> - <i>Coupling nuts</i>
6	2 x 3 staffe dentate - <i>Stufenklemmen</i> - <i>Step clamps</i>
12	2/2 x 3 appoggi a gradino - <i>Stufenauflagen</i> - <i>Step blocks</i>



Coppie staffe di bloccaggio ad U - 2 piastre in ottone salvapezzo - rondelle sferiche - tiranti - dadi a T - cartone
Paar U-Klemmbuegel - 2 Schutzplatten aus Messing - kugelfoermige Unterlegscheiben - Schrauben - T-Muttern - Karton
Couples of joint U-clamping - 2 brass protection plates - round washers - screws - T-nuts - carton box

Codice N° <i>Bestell Nr.</i> <i>Order code</i>	Pezzi <i>Stueck</i> <i>Pieces</i>	Vite <i>Schraube</i> <i>Screw</i>	dado "T" <i>T-Mutter</i> <i>T-nuts</i>
008.052	2	M12	T14
008.053	2	M12	T16
008.056	2	M16	T18
008.057	2	M16	T20
008.058	2	M18	T18



Coppie staffe di bloccaggio ad "U"

Paare U-Klemmbuegel
Couples of joint U-clamping

Midway
677

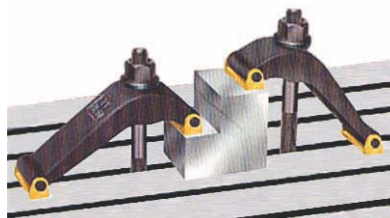

008.056

Durometri da banco Rockwell - lettura 0,5HR - carichi 60-100-150Kg - dimensione massima pezzo 250x170h
 durometro 185x465x640h - cassa di legno
Haertepruefgeraet Rockwell - Ablesung 0,5HR - Pruefegewichte 60-100-150Kg - Maximalgroesse Pruefstueck 250x170h
Groesse Geraet 185x465x640h - Holzkasten
Rockwell hardness testers - reading 0,5HR - test forces 60-100-150Kg - max. dimension of piece to be measured 250x170h
size of testing machine 185x465x640h - wooden case

Codice N° <i>Bestell Nr.</i> <i>Order code</i>	HRC	HRB	HRA
009.400	20-70	25-100	20-88



Durometri da banco HRC

Haertepruefgeraete Rockwell
Rockwell hardness testers

Midway
600



009.400

Accessori standard: 1 penetratore a diamante - 1 penetratore a sfera - 2 incudini piani - 1 incudine a V - 5 blocchetti di taratura - 1 valigetta
Standardzubehoer: 1 Diamantmesskopf - 1 Kugelmesskopf
2 Messtische flache Ausfuehrung - 1 Messtisch mit Prisma
5 Testbloecke - 1 Alukoffer
Standard accessories: 1 diamond penetrator - 1 ball penetrator
2 flat anvils - 1 anvil with v-block - 5 hardness testing blocks
1 aluminium bag

009.401	Pen.diam.- <i>Diamantpen.</i> - <i>Diamond pen.</i>
009.402	Pen.sfera. - <i>Kugelpen.</i> - <i>Ball pen.</i>
009.403	Blocchetto - <i>Pruefstueck</i> - <i>Test block</i>
009.404	Comparat. - <i>Pruefuhr</i> - <i>Dial indicator</i>



Ultimi arrivi - novità

Letzte Ankuenfte - Neuigkeiten
Last arrivals - news

Correzioni ed annotazioni

Korrekturen und Anmerkungen
Corrections and notes
